

A close-up photograph of a yellow Sakai ER555F-s forklift. The image shows the side of the machine, including the body panels, ventilation grilles, and two large, black, treaded tires. The text 'SAKAI ER555F-s' is overlaid in bold black font on the left side of the image.

SAKAI
ER555F-s



GLOBAL ALDER



ERBUT



SAKAI HEAVY INDUSTRIES, LTD. Over 100 Years in the making...

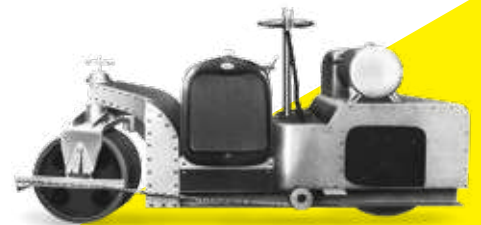

1929-30

Internal combustion engine tandem and macadam roller

Historic crossroad in the development and production of rollers powered by internal combustion engine, making Sakai the pioneer in road construction machines.



1925

Sakai Trademark

SKW trademark was created, symbolising the establishment of Sakai Heavy Industries as a full-fledged manufacturer.



1918

Sakai Kinnoyuki

Equipped with skills with machinery and great foresight, Sakai Kinnoyuki founded Sakai Heavy Industries.



1964

Listed on TSE

Sakai Heavy Industries went public and was listed on the Tokyo stock exchange in 1964 and was later reclassified as a prime stock company in 1981.

1945-46

Sakai Tomoyoshi

Sakai Tomoyoshi restructured the business and restarted the manufacturing of Tandem Roller despite the tough economical situation.

1935

Overseas Export

Sakai Heavy Industries started exporting their road rollers in 1935, whilst refining the product line and technology behind the company's success.



A message from our president Sakai Ichiro

Elected as President of Sakai Heavy Industries in 1995, Sakai Ichiro incorporates his core principles to the way he manages Sakai Heavy Industries.



- 1 "Honestly and Righteous"- To live and act with nothing to hide
- 2 "Seeking purpose in society" and by doing so, also returning to society
- 3 Brush up our company's significance and continue its improvement by "Refining expertise"
- 4 Cherishing the people around oneself
- 5 "Adaptability"- To have the foresight and flexibility to advance with technology and society
- 6 Understand "天時、地利、人和" (opportune time, geographic advantages, harmony among people) and act carefully and boldly
- 7 "Simple is the best"- Not over complicating things is key to user experience

50 THE DNA OF ER



1972
ER160

The ER160 was developed to repair roads where rutting and damage to the pavement surface had become significant due to increased traffic volume and larger vehicles.



1982
ER300



2003
ER551F



1996
ER550F

2000
ER570CF



2007
ER552F



2012
ER552F-1



2017
ER555F

Automatic Cutting Control System (ACCS) and other advance features.

1988

ERF600



ERF300 features the function of both road cutter and feed loader, making it possible to cut roads and expel cut asphalt.

1986

ERF300



1989

ER500F



1994

ER501F



1992

Produced crawler-type road cutter. **ER750CF**



2023

ER555F-s



50 years of the innovation >>>



EVOLUTION

SAKAI Road Cutter (ER) evolved through the company's long history, refined over the decades, and finally spreading wings around the world cutting with Japanese precision.





MAKING THE IMPOSSIBLE POSSIBLE





SSIBLE

Whether its a bump in the road or a 30 cm step, nothing stops the ER555F-s from completing its task so cutting off a flat surface. This may seem impossible, but SAKAI's ER555F-s is designed to maintain balance and stability even in the most extreme cases. We work to shape the land, not work around the shape of the land.

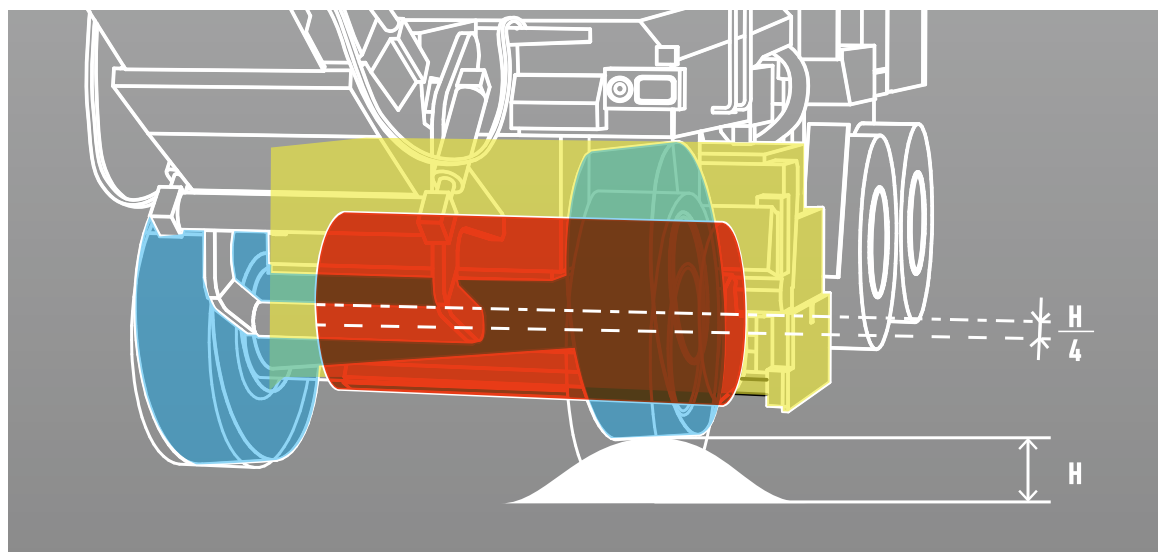

/ Bogie system

Designed based on the bogie system, in the event that a tire on one side is raised the elevation experienced by the drum is only $\frac{1}{4}$ the elevation of the wheel. This reduces any disturbance to the cutter drum during operation providing a uniform finish.



SAKAI
ER555F-s

ONE MACHINE ONE



MISSION ONE MAN

ONE MAN OPERATION

Automatic Cutting Control System



ACCS IV



- Displayed in millimeters (mm) for the finest adjustments
- Manual operation is also possible for uncommon work conditions
- Easy setting (zero-ing / depth setting can be saved)
- Can be operated on either side

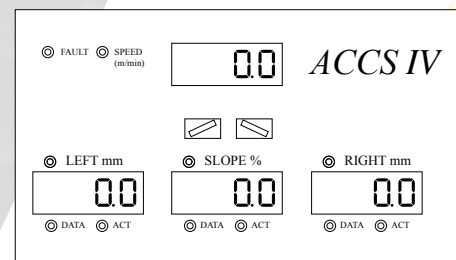

Control Panel



- The control panel gives you control over the cutter drum, side cover, conveyor and steering.
- The forward-reverse lever is located within arms length of the control panel.

The digital monitor makes it easy to determine the slope (%)

- Manual mode: current slope based on sensor
- Automatic mode: target slope figure or current value based on the sensor signal





A DIFFERENT CUT

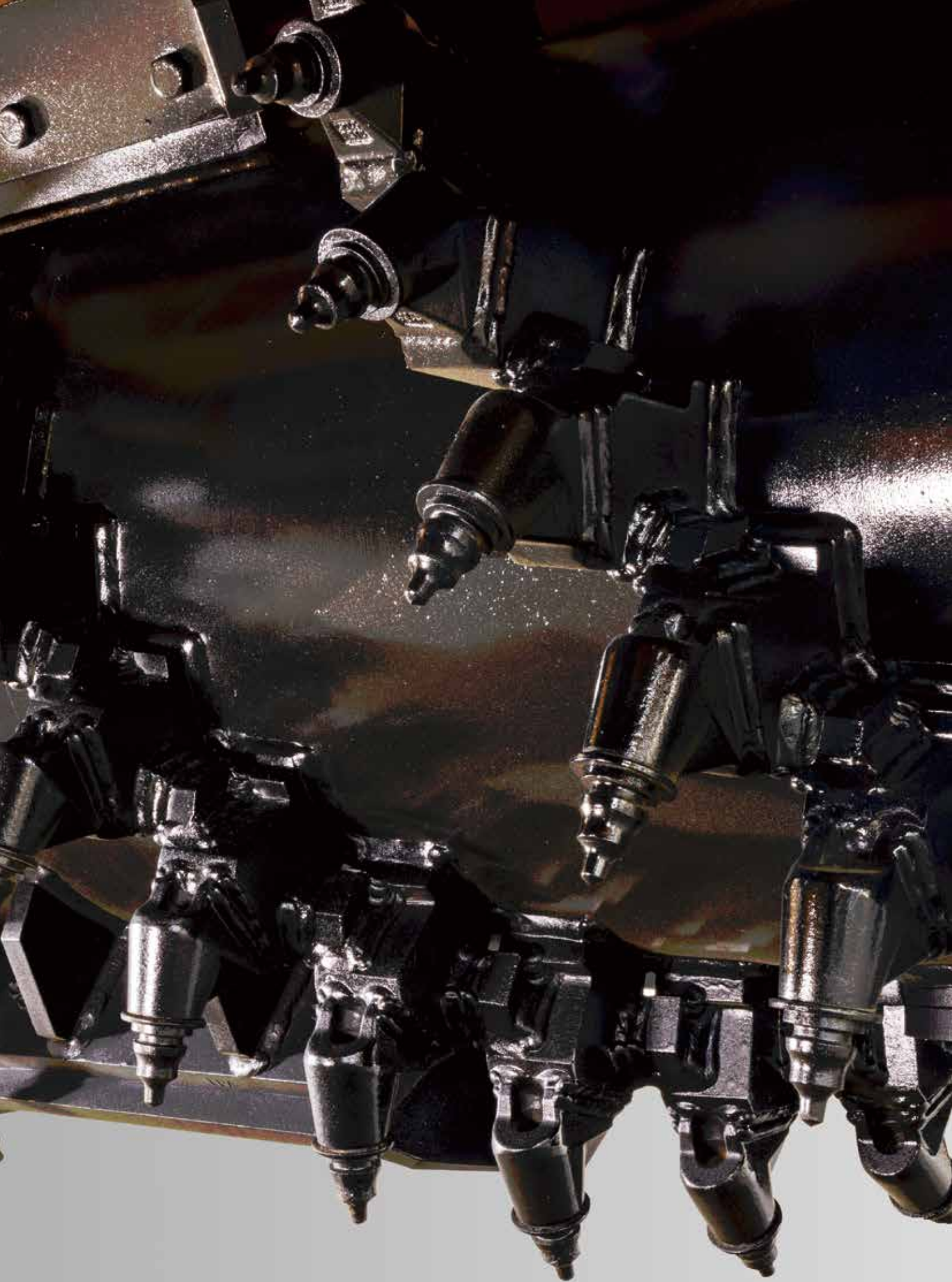



Safe and Secure

The Cutter drum's side shift function allows cutting to be done safely even on the shoulder of a raised road. Using these heavy machines on the absolute edge of raised ground is dangerous as there is a risk of overturning. With the ER555F-s side shifting abilities, cutting can continue in relative safety.



Drum Shift (either left & right) : 450 mm

SIDE SHIFT

CUTTING EDGE INNOVATION

No side shift

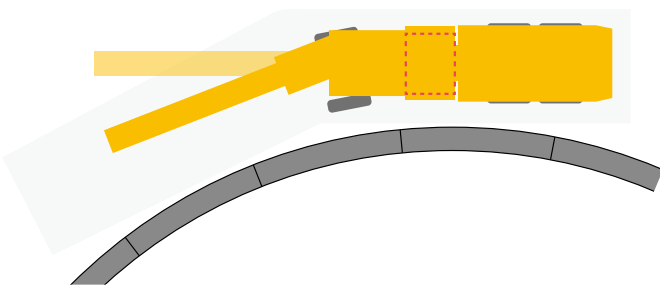

With side shift (450 mm)

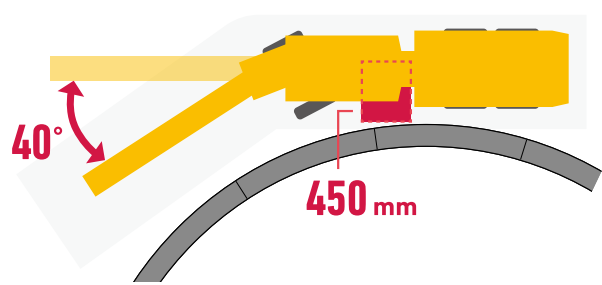

Cut on the curve

Cutting on curves using side shift provides more efficiency. The conveyor swings 40° expelling cut asphalt onto dump trucks even on narrow roads with curves.

DRUM

Cutting Depth (MAX): 230 mm

Cutting Width: 2,050 mm





Hydraulic drive allows for finer control over the cutter drums and reduces wear and stress on the main engine shaft, ensuring longevity and precision.

Precision allows ER555F-s to cut accurately down to the millimeter.







MOBILITY



- ▀ Driving speed : Max 27 km/h
- ▀ The drum can be side-shifted, providing versatility on roads where there is a lot of obstruction.
- ▀ High maneuverability allows the ER555F-s to move between jobsites without the need for transport, saving both time and cost.
- ▀ Conveyor folds over the top for easy loading and unloading onto flatbeds. ER555F-s's low transport weight means it can be transported via smaller transports.



ER555F-s can travel 3 km in about 10 minutes, making it faster and more cost-effective to drive than waiting for a transport trailer.

* Calculated with considerations of traffic situation

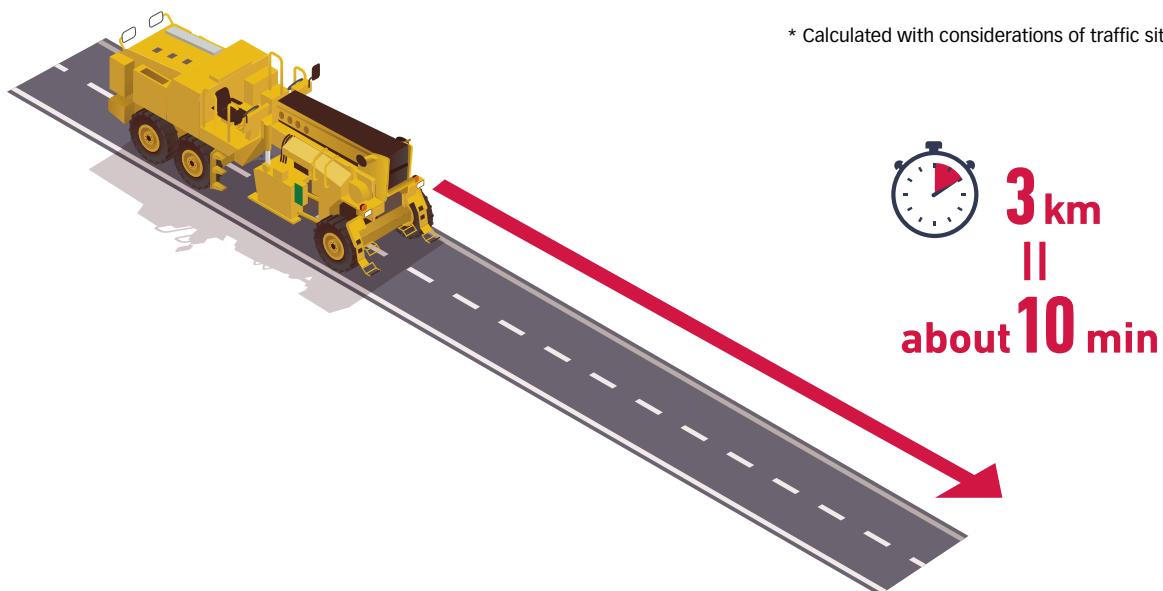





The rear gate retracts and opens wide providing ample space to check and service the drum on-site.

Designed for quick and easy maintenance, the engine compartment can be directly accessed by opening the bulkhead on either side. Ergonomic placement of filters makes it easy to exchange, reducing servicing time and increasing productivity.

MAINTENANCE

OPTION

Mi-Ha-Ru (Ultrasound radar)



Safety Bumper



Air Compressor



Camera System

Side monitor



Neutral mode



Forward mode



Reverse mode

Dashboard monitor



Neutral mode



Forward mode



Reverse mode

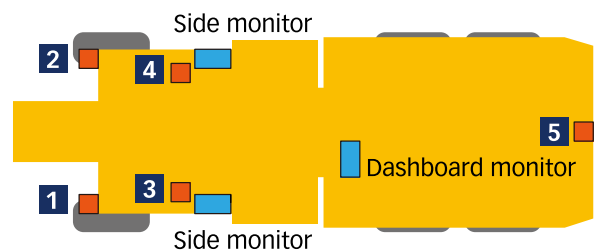
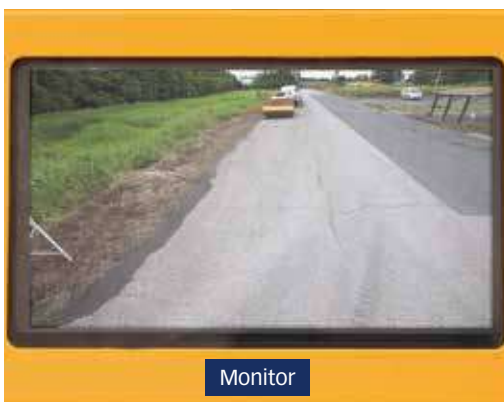
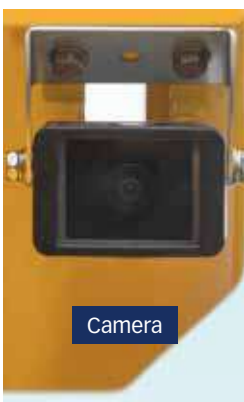

Other option equipment

- Dust Collector

Other standard equipment

- 24V Accessory Socket



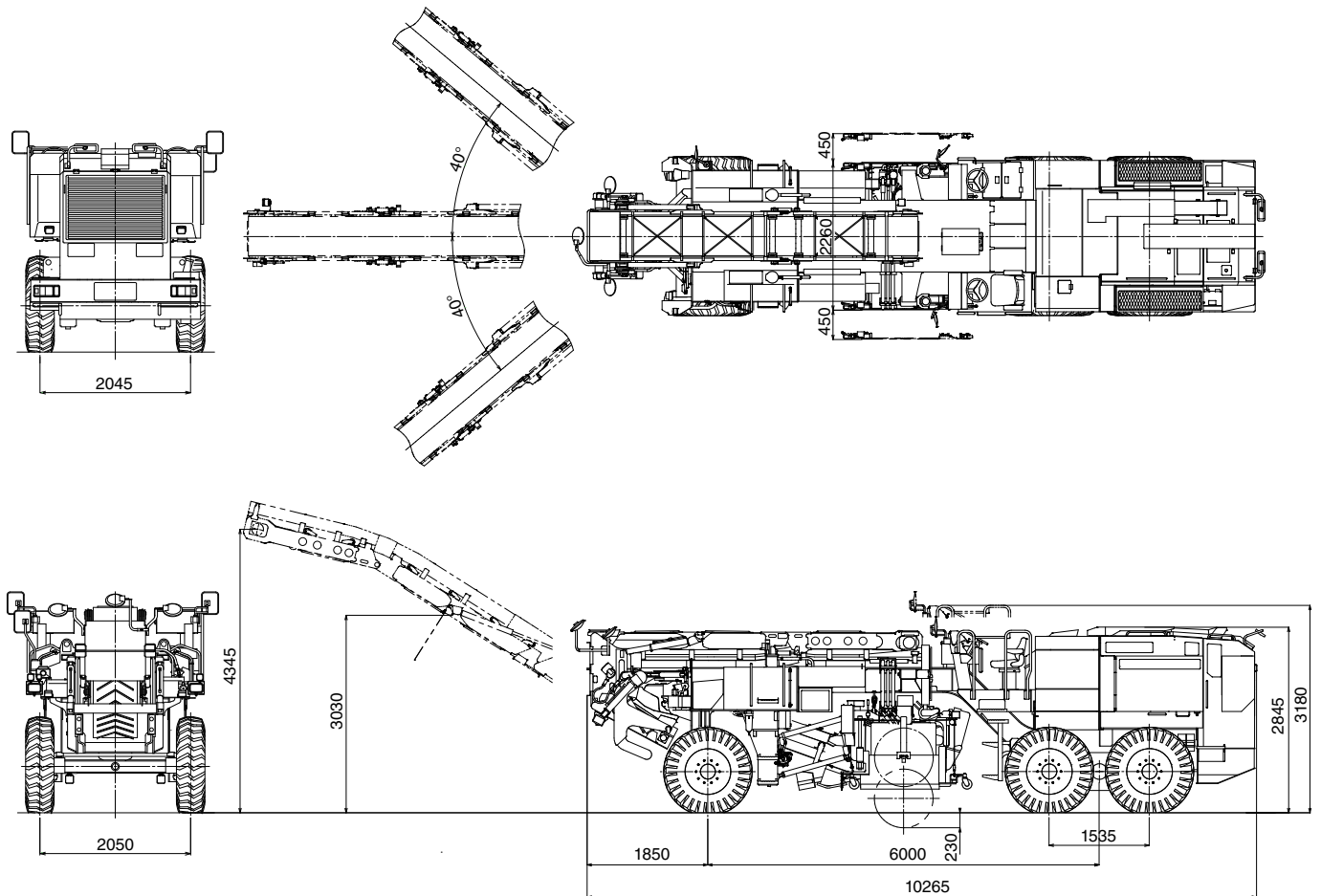

unit : mm

TYPE		Road Cutter	
MODEL		ER555F-s	
CHASSIS MODEL		1ER14	
WEIGHTS	Max. operating weight	kg (lbs)	27,950 (61,620)
	Operating weight	kg (lbs)	25,950 (57,210)
	Load on front axle (operating weight)	kg (lbs)	11,200 (24,690)
	Load on rear axle (operating weight)	kg (lbs)	16,750 (36,930)
PERFORMANCE	Speed range (travel)	km/h (mph)	0-27 (0-16.8)
	Speed range (operating)	m/min (ft/min)	0-55 (0-180)
	Gradability	% (°)	42 (23)
	Min. turn radius (outer)	m (in)	11.6 (457)
DIMENSIONS	Overall length	mm (in)	10,265 (404)
	Overall width	mm (in)	2,460 (97)
	Overall height [operate / shipping]	mm (in)	3,180 / 2,845 (125 / 112)
	Wheelbase	mm (in)	6,000 (236)
	Tire size × Number of tires		14.00 - 24-16PR(OR)×6
	Inflation	kPa (psi)	600 (87.0)
CUTTER SYSTEM	Cutting width	mm (in)	2,050 (81)
	Cutting depth [max.]	mm (in)	230 (9.1)
	Shift stroke	mm (in)	450 (17.7)
	Number of bit	pcs.	142
	Curb clearance	mm (in)	400 (15.7)
	Side clearance	mm (in)	105 (4.1)
	Water sprinkler system		pressure type
LOADING SYSTEM	Belt width	mm (in)	600 (23.6)
	Loading height	mm (in)	4,345 (171)
	Swing angle	°	40
ENGINE	Make		KOMATSU
	Model		SAA6D140E-5
	Type		Diesel, water cooled, 4 cycle, 6 cylinder, with turbo charger
	Displacement	L (cu.in)	15.24 (930)
	Rated output	kW (HP) / min ⁻¹	370 (496) / 1350
	FLUID CAPACITY	Fuel tank	L (gal)
Hydraulic tank		L (gal)	350 (92.4)
Sprinkler tank		L (gal)	2,000 (528.3)

- Specified figures have a tolerance of ±5%.
- All specifications may be changed without notice.
- Specified figures are in SI Units, followed by their equivalent in English units of measurement in parentheses.

- Max. operating weight : Fuel=100%, Water=100%, Operator=75 kg
- Operating weight : Fuel=50%, water=50%, operator=75 kg
- The photos may contain optional equipment and/or attachment.



NOT JUST



SAKAI

TROLLERS

JAPAN

SAKAI HEAVY INDUSTRIES, LTD.

Tel +81-3-3431-9971
www.sakainet.co.jp/en/

INDONESIA

PT. SAKAI INDONESIA

Tel +62-21-897-0374, 897-1778
www.sakai.co.id

PT. SAKAI SALES AND SERVICES ASIA

Tel +62-21-897-0374, 897-1778
www.sakai.co.id

U.S.A

SAKAI AMERICA, INC.

Tel +1-770-877-9433
www.sakaiamerica.com

CHINA

SAKAI HEAVY INDUSTRIES(SHANGHAI), LTD.

Tel +86-21-6916-9808
www.sakai.com.cn



**SERVICE
HOTLINE**

If you need any technical or service parts support
on our products, please contact this web page.

www.sakainet.co.jp/en/